

FLF204

Universal Loadcell

Standard Ranges 1, 2.5, 5, 10, 25 and 50tonne (10 to 500kN)

- Large internal interfacing threads
- High structural load limit
- Flying lead or connector option
- Sealed to IP65
- Standard 2 year warranty



ALTHEN
 MESS- UND SENSORTECHNIK

Geometry: Axial strain cylinder in a weather sealed stainless steel case, with end internal fixing threads. [For use in tension and compression loaded in line with the axis. With bi-directional versions there is a small difference between the output signal for compression and tension. All standard bi-directional loadcells are calibrated in both modes and the output for each direction is stated on the test / calibration certificate.

The FLF204 is ideally suited to bi-directional engineering force measurements. They are used extensively within the automotive industry for testing of auto components. Standard rod end bearings are available for this product. If you require better performance than the FLF204 the FLF317 may be suitable.

We are happy to design variants of this loadcell to meet your specific requirements. Versions can be manufactured for fully compensated operation up to +250°C. Please consult our engineering department.

RANGE	A	B	C	D	E	F	G
1, 2.5, 5 TONNE	110	80	13	42	M24 x 2 x 38	28	32
10, 25 TONNE	140	98	19	82	M48 x 2 x 47	48	65
50 TONNE	180	128	24	113	M64 x 3 x 65	64	90

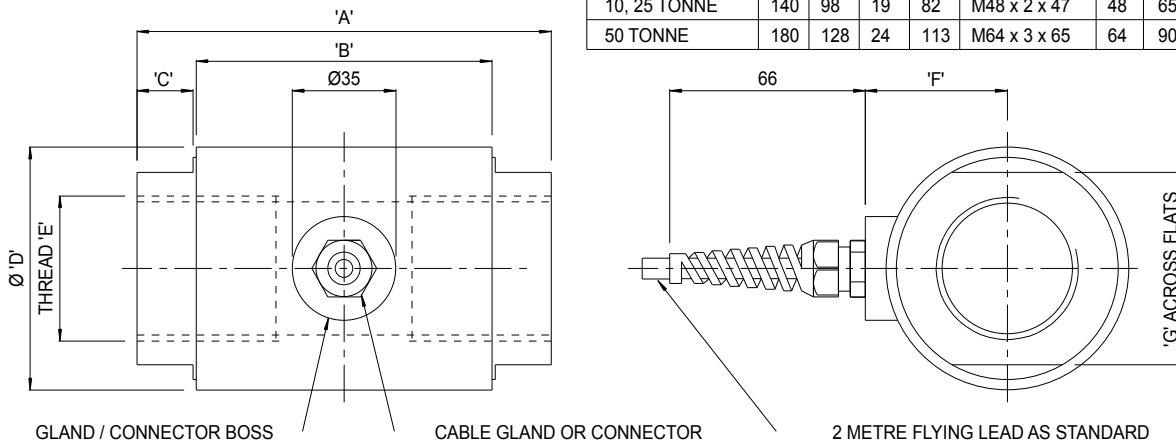

■ Specifications

Parameter	1 to 10tonne	25 to 50tonne	Unit
Non-linearity - Terminal	±0.2	±0.5	% RL
Hysteresis	±0.2	±0.5	% RL
Creep - 20 minutes	±0.05	±0.05	% AL
Repeatability	±0.02	±0.03	% RL
Rated output - Nominal	1.2	1.2	mV/V
Rated output - Rationalised	1.0	1.0	mV/V
Rationalisation tolerance	±0.5	±0.5	% RL
Zero load output	±4	±4	% RL
Temperature effect on rated output per °C	±0.005	±0.005	% AL
Temperature effect on zero load output per °C	±0.03	±0.03	% RL
Temperature range - Compensated	-10 to +50	-10 to +50	°C
Temperature range - Safe	-10 to +80	-10 to +80	°C
Excitation voltage - Recommended	10	10	V
Excitation voltage - Maximum	20	20	V
Bridge resistance	700	700	Ω
Insulation resistance - Minimum at 50Vdc	500	500	MΩ
Overload - Safe	50	50	% RL
Overload - Ultimate	200	200	% RL
Sealing	IP65	IP65	
Weight - Nominal (excluding cable)	1 to 3.2	4 to 15	kg

All standard ranges are manufactured in stainless steel.

Structural stiffness – Nominal					
Range (kN)	Stiffness (N/m)	Range (kN)	Stiffness (N/m)	Range (kN)	Stiffness (N/m)
10	2.8×10^8	100	2.7×10^9		
25	7.0×10^8	250	6.8×10^9		
50	1.4×10^9	500	1.4×10^{10}		

■ Notes

1. AL = Applied load.
2. RL = Rated load.
3. Temperature coefficients apply over the compensated range.
4. The load must be applied directly through the central loading axis.

■ Connections

The loadcell is fitted with 2 metres of PVC insulated 4 core screened cable type 16-2-4C or a 4 pin Binder 723 series chassis plug.

Excitation + = Red or pin 1 Signal + = Yellow or pin 3 Screen = Orange
 Excitation - = Blue or pin 2 Signal - = Green or pin 4

Reverse the signal connections to obtain a positive signal in tension mode.
 The screen is not connected to the loadcell body.

■ Ordering codes

See the loadcell ordering code sheet for more details. Add range in the required units.			
FLF204CFR0K0	Compression, IP65, unrationalised	FLF204CFR0KN	Compression, IP65, rationalised
FLF204TFR0K0	Tension, IP65, unrationalised	FLF204TFR0KN	Tension, IP65, rationalised
FLF204UFR0K0	Bi-directional, IP65, unrationalised	FLF204UFR0KN	Bi-directional, IP65, rationalised
Change ..FR0K0 to ..PR0K0 or ..FR0KN to ..PR0KN for the connector version.			

Feteris Components B.V.

Scheveningseweg 15 ☎ +31 70 3924421
 2517 KS The Hague ☎ +31 70 3644249
 The Netherlands

🌐 www.feteriscomponents.com
 📧 sales@feteriscomponents.nl

Offices in : Benelux | France | Germany | United Kingdom | USA | Italy

FETERIS *Components*
Sensors & M.M.I. Products